

THE CLUB	OLD BIKES	NEW BIKES	DIARY	LINKS	FORUM	PHOTOS
----------	-----------	-----------	-------	-------	-------	--------

[Morini Riders Club](#) / [The Old Bikes](#) / [Technical tips](#) / [KickStarter](#)



The logo used from 1968 to 1973. The falcons body is placed centrally in the badge.

## Re-assembly of kickstart mechanism

Install spring, inner and outer plates and ratchet on the shaft. The ratchet should be fitted as shown in Fig 96.

The complete kickstart shaft assembly should be fitted proceeding as follows. Place the kickstart gear in its working position and insert the end of the shaft into the hole of the gear. Install the spring anchor pin in its housing and engage the end of the kickstart spring to the pin.

After left hand cover replacement, fit the pedal on the shaft placing it in the proper position. **Note that the return travel of the pedal should be stopped by engine left hand cover and not by the lug on the ratchet cam (fig 98-99)**

Instructions from the Blue workshop manual.

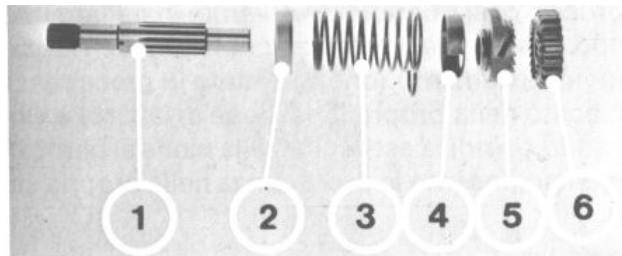

Fig. 95

- 1) Albero avviamento  
Kick-starter shaft
- 2) Piattello esterno  
Outer collar
- 3) Molla  
Spring
- 4) Piattello interno  
Inner collar
- 5) Manicotto con innesto a denti frontali  
Ratchet
- 6) Ingranaggio  
Kickstarter pinion

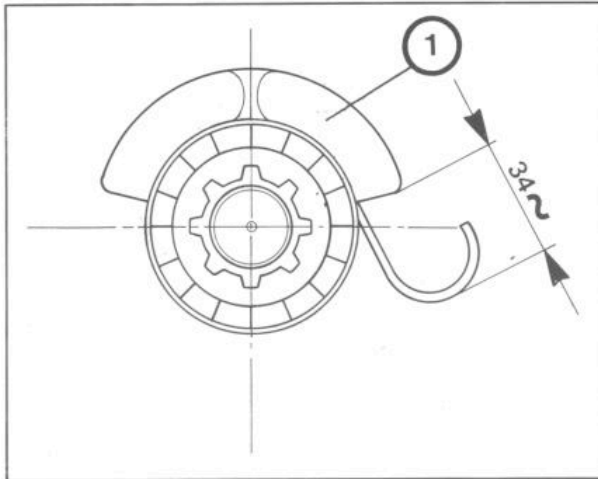
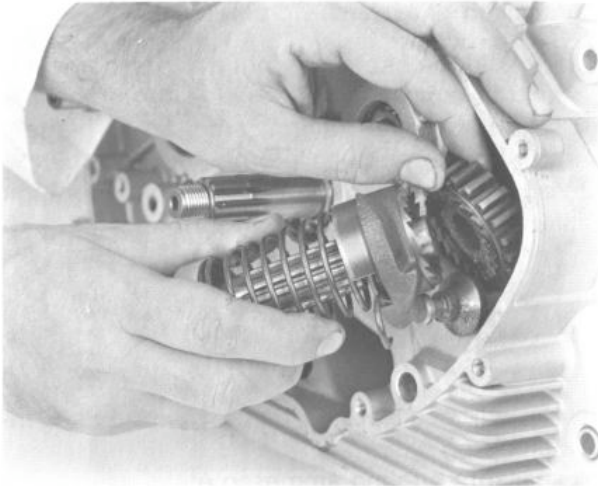
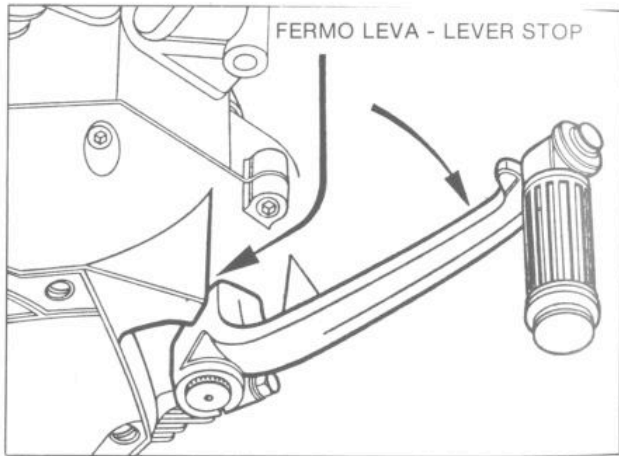
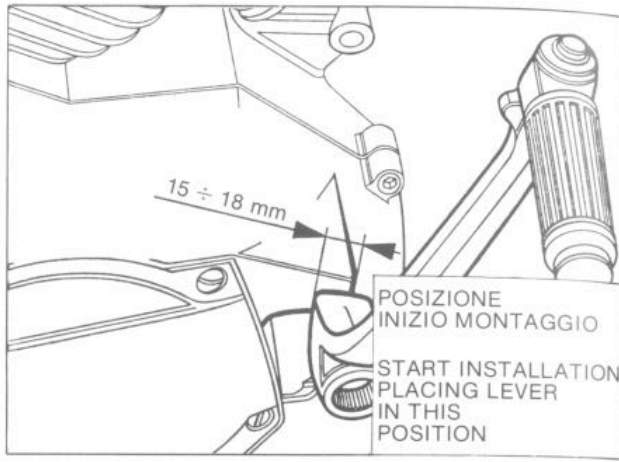

Fig. 96

Posizione molla al montaggio (tutti i modelli)  
Spring end location (all models)

- 1) Camma dell'innesto a denti frontali  
Ratchet cam





**Fig. 98/99**

Montaggio leva avviamento a pedale  
Kickstarter lever installation

[TOP](#)